

THE HORIZON



80mm & 100mm Installation Guide

Minimum 2 installers required

1. Screens are tested prior to packaging.
2. Store screens in original packaging until installation.
3. Inspect all products and components prior to installation.
4. **Photograph and Report** damaged or missing parts *immediately* to orders@wizardscreens.com
5. Preferably install screen after door is installed.
6. **Do NOT draw out screen until tracks are installed.**
7. If affixing screen system directly onto door frame and threshold, ensure fastening will NOT negatively impact the performance of the door and hardware. Consult door manufacturer.
8. Do NOT increase tension beyond 5 seconds on SLOW speed.



Spray tracks *only* with dry silicone.

If you have questions, refer to the [troubleshoot manual](#) and [maintenance & service guide](#) first. If necessary, contact support **while on-site: support@wizardscreens.com **604-299-8878****

CLICK



If troubleshooting, do ***NOT*** increase spring tension until **troubleshoot manual** steps have been thoroughly reviewed and practiced where applicable.

If it must be attempted, do ***NOT*** add more than 10 seconds on **LOW SPEED**.

Otherwise, the spring may break!

If there are still issues, contact product tech support.

REQUIRED



Level



Tape Measure



Pencil



Mallet



9/64 and 1/8
Drill Bits



#1 and #2
Robertson
Driver Bits



Dry Silicone
Spray



Small
Countersink Bit



Flat Pry Bar



RECOMMENDED

2-way Laser Level Kit



Chop Saw

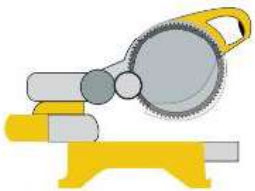

Drill



Step Ladder



Vacuum



Filer



Laser Distance Measure





- 1) Position **Alignment Jig**.
- 2) Fasten locators, “B”, in place.
 - A) Front locator is fastened with 3 screws.
 - B) Rear locator is a single screw (may be omitted).

The housing must be able to sit flat and be plumb.

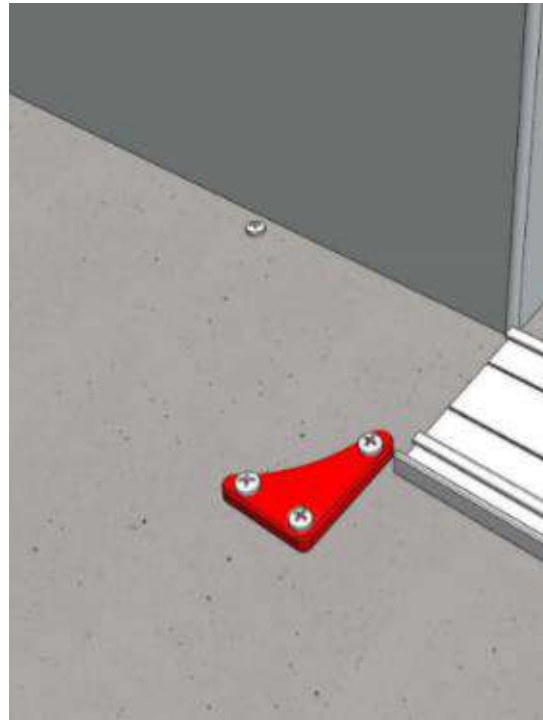
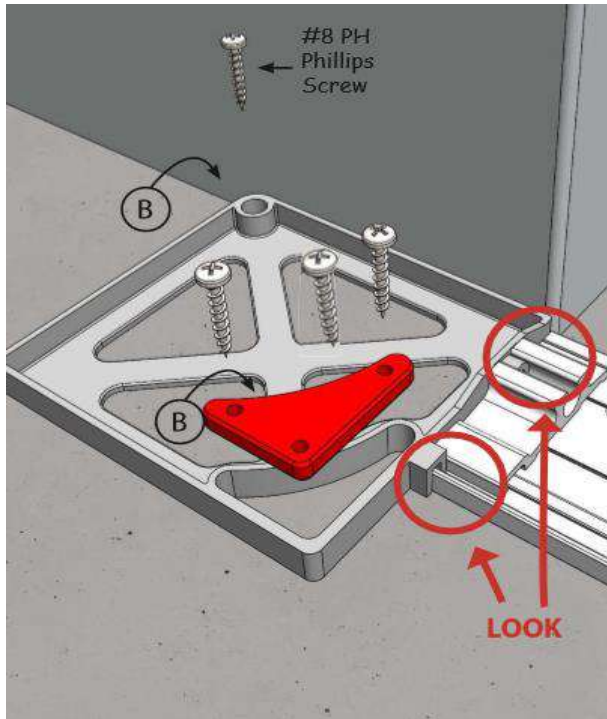

***TIP:** Short cut-off of both **lower fixed track mount** *and* **lower track** will help position the Alignment Jig if those are at your disposal. Then you can measure from Alignment Jig to where receiver or corner joiner will be. (see “Measure Tracks” later).

Keep cut-off for future installs

1. Push **housing** firmly down.
Bottom of both **lower track** and **housing** will have to be even.

2. Plumb **housing**.
3. Fasten with #8 screws. Ensure **housing** does *not* twist when doing so. Relieve if necessary.

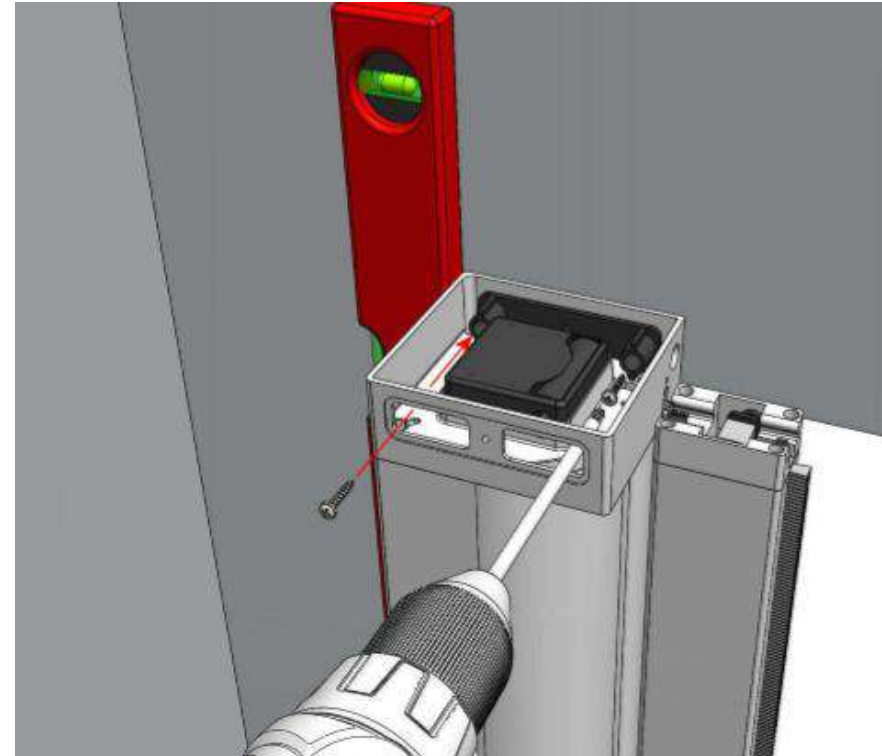
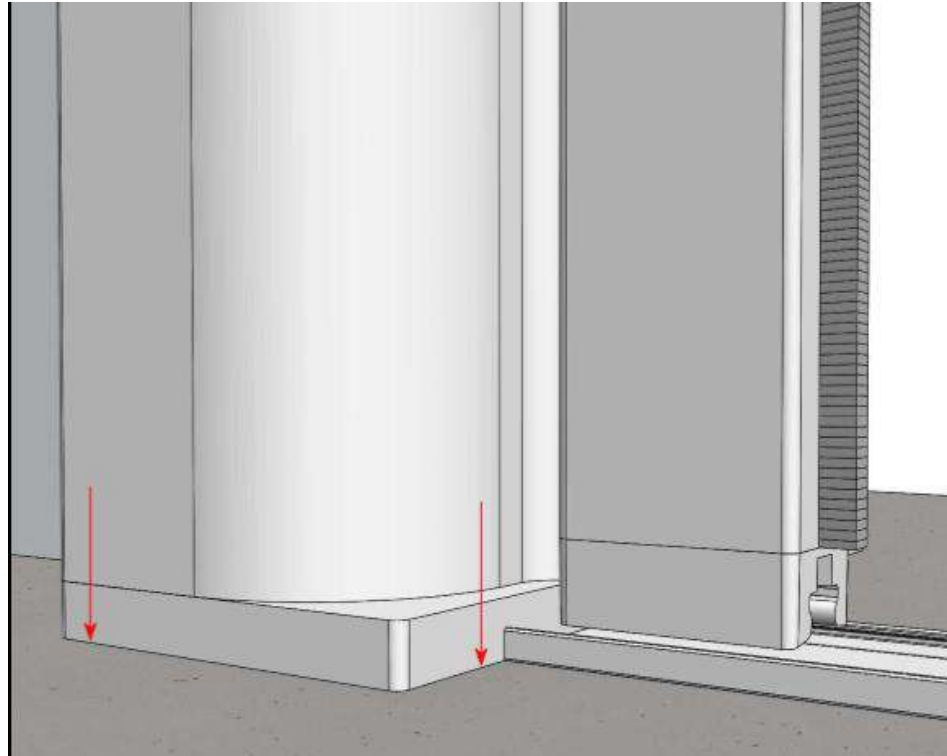

The housing must sit flat and be plumb both ways.



1. Remove the **backer plate**.
2. Predrill a hole through the **housing endcap**.

*NOTE: 80mm Horizons *cannot* be mounted this way. Only as per previous page.

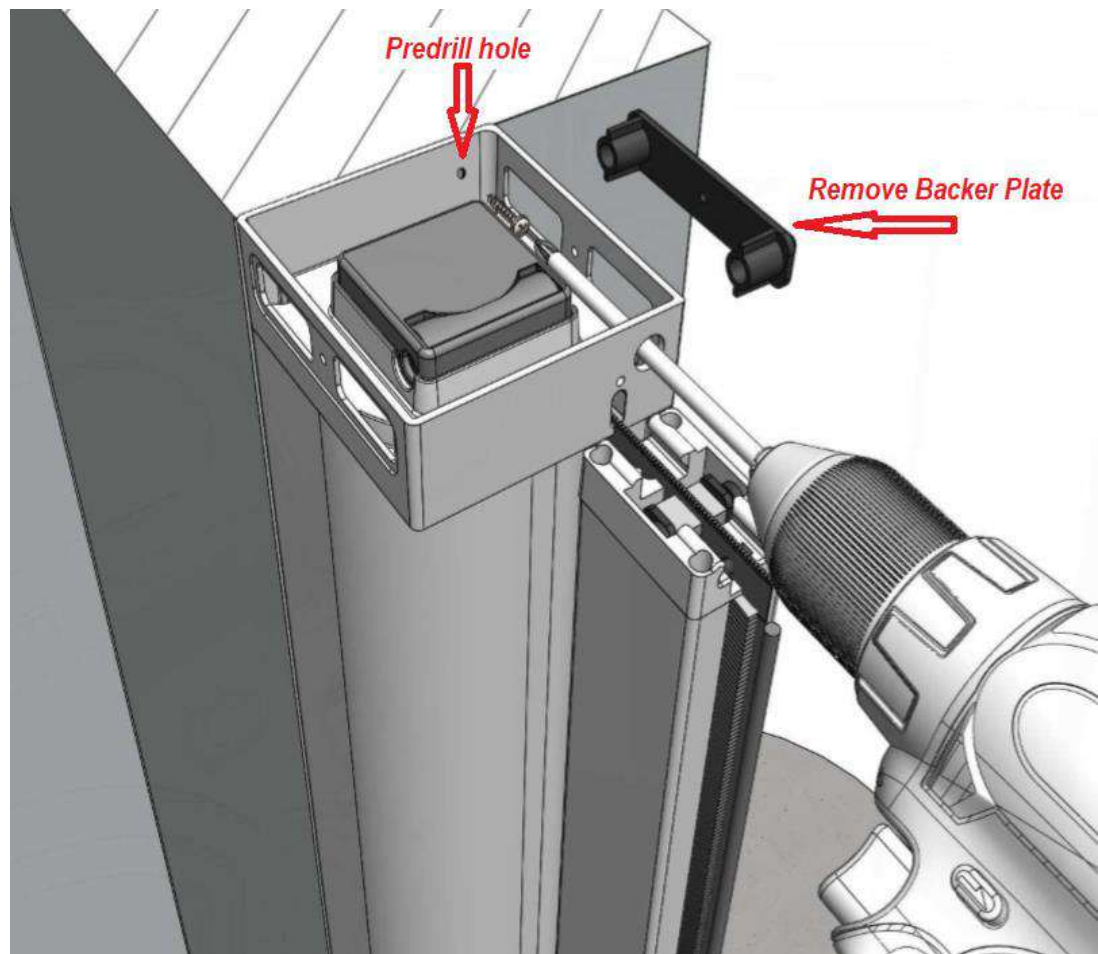

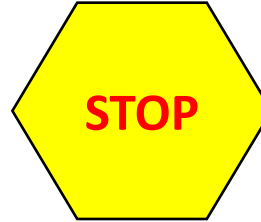

Check the mesh slot in the **housing** – if the **housing** has been twisted or forced into the opening during the install, the slot may get squeezed smaller. This will prevent the screen from operating smoothly or at all. If twisted, try to relieve **housing screw**.

First re-install the **housing** with this consideration. Otherwise, see the [maintenance and service guide](#) on our [technical site](#) for how to increase the gap using spline.

Do NOT draw out screen until tracks are installed.

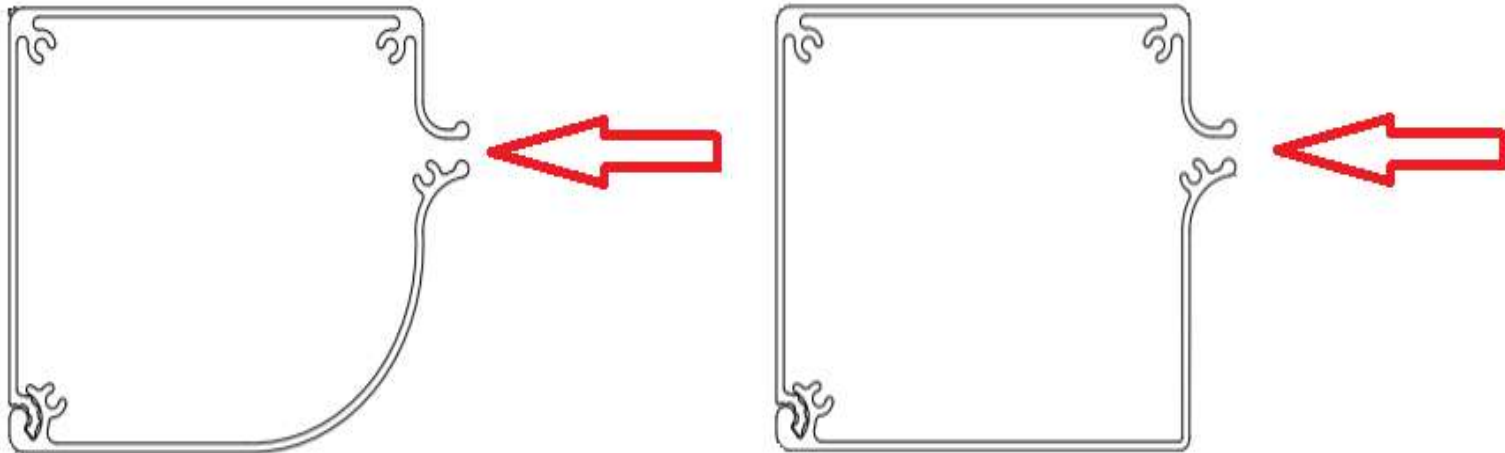



If receiver side of jamb is *not* plumb, put a plumb mark at top or bottom to match part of jamb that is **closer to housing** and measure to that.

or Housing

Can be offset
or centered

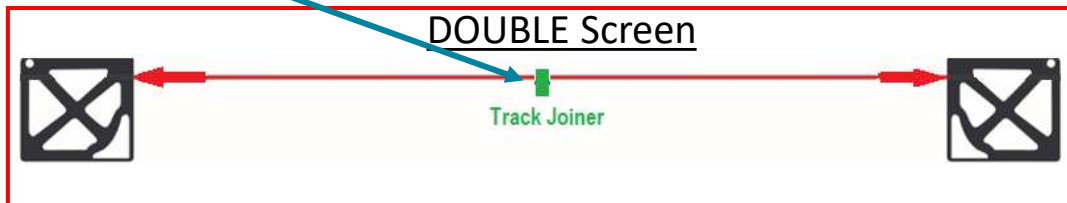
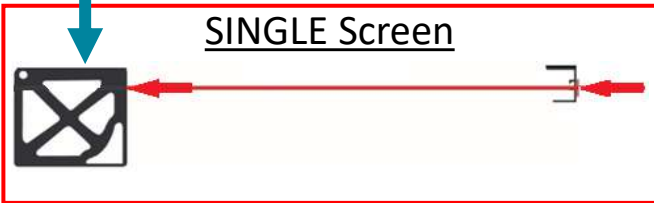

NOTE
Assuming **housing is plumb**, **upper & lower track** must be cut to the same length for that unit.

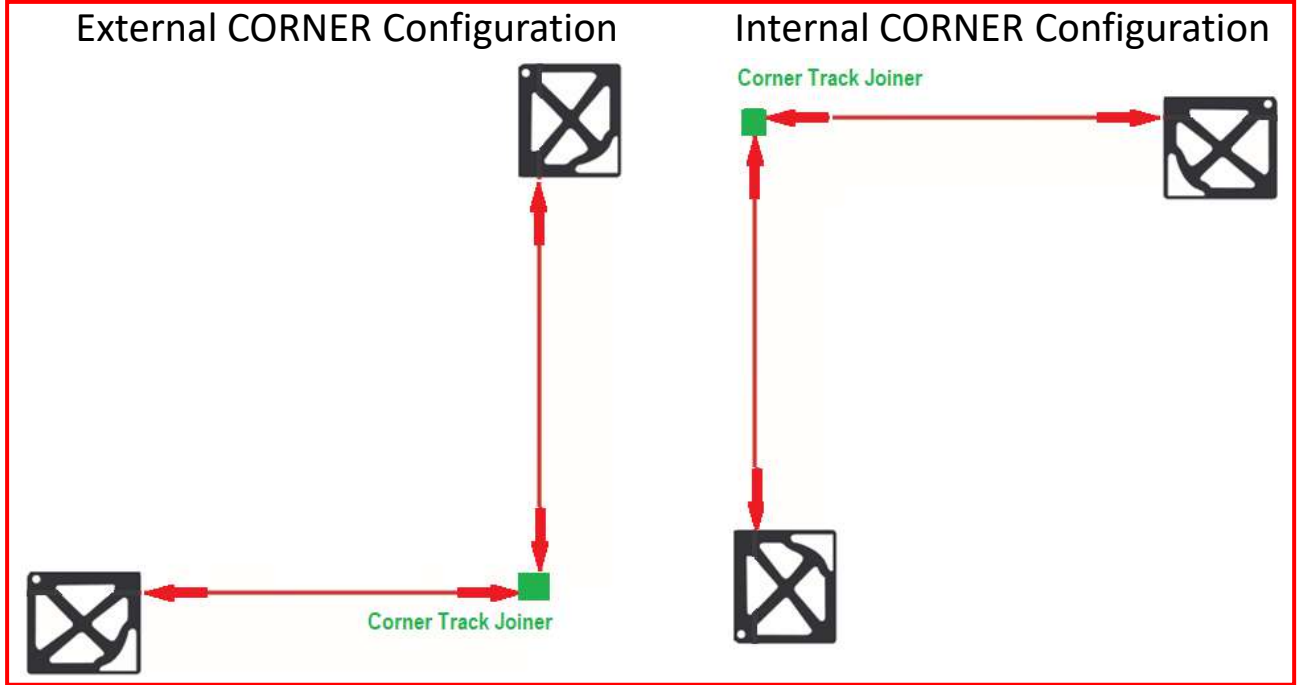

UPDATE

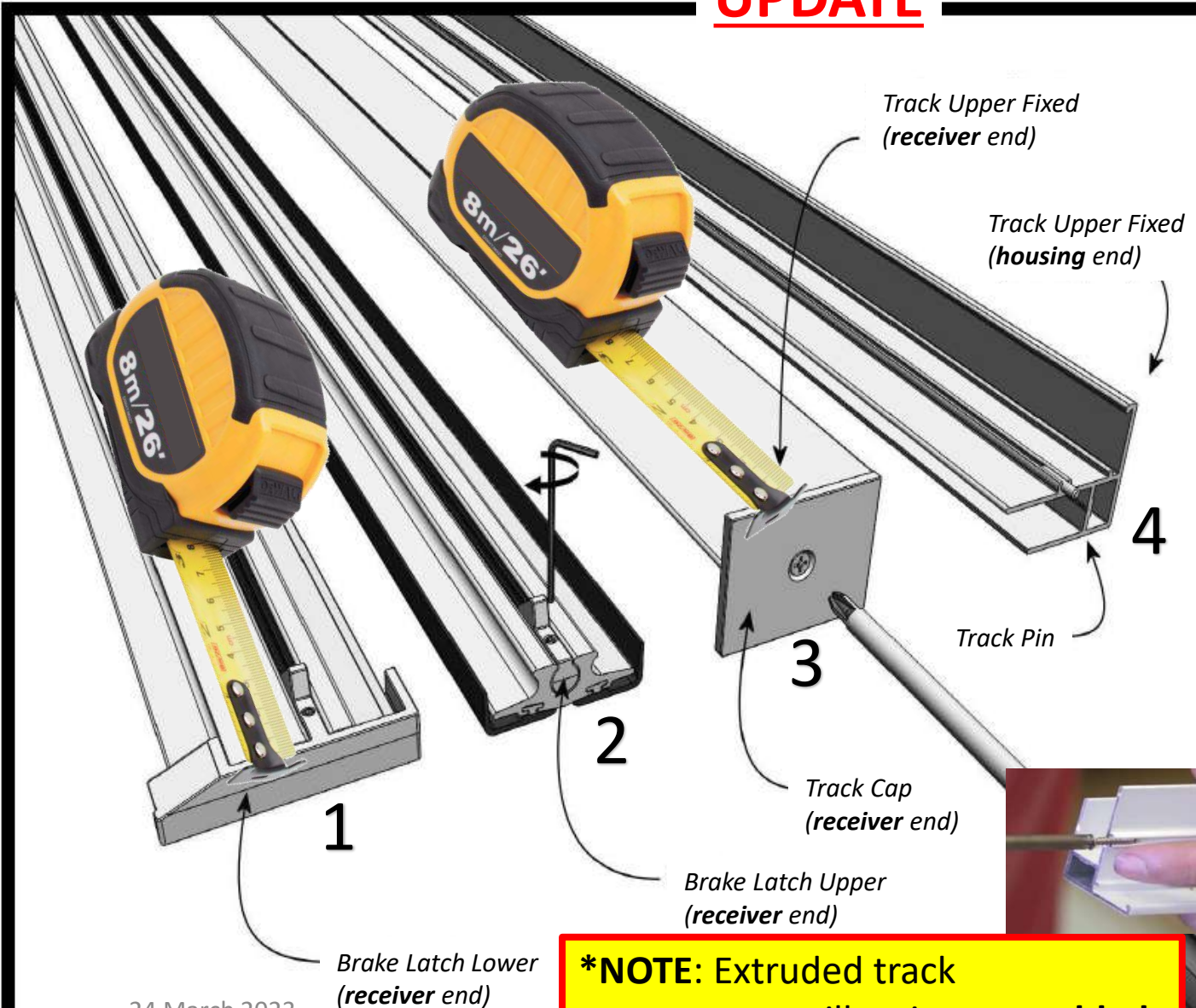

1. Cut or file off any excess paint on end of tracks.
2. Put track parts 1,2,&3 onto **receiver** ends of the track components. 1.5mm allen key to attach latches.
3. Measuring from both Brake Latch Lower and Track Cap Upper, mark at determined identical length.
4. Put Upper and Lower Track components together respectively.
5. Flush the components at **receiver** ends of tracks. Cut at mark.
6. On **housing** end of Track Upper Fixed, widen hole using #6 ST screw. Insert Track Pin (4).

***NOTE:** Extruded track components will arrive **assembled**.

UPDATE

Lower track **mount** butts into each other and joiner sits *on top* of that. **Tracks** cut to fit in between **joiner**.

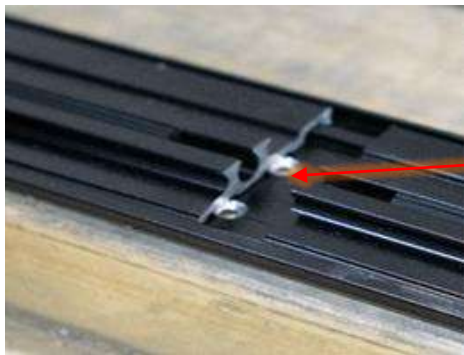

	Standard	Internal Corner	External Corner
UPPER			
LOWER			

OR

Track mount and track cut to same length to fit between **joiner**.

DO NOT CUT TRACKS AND RUNNERS TOO SHORT

*Lower corner joiners as shown on previous page

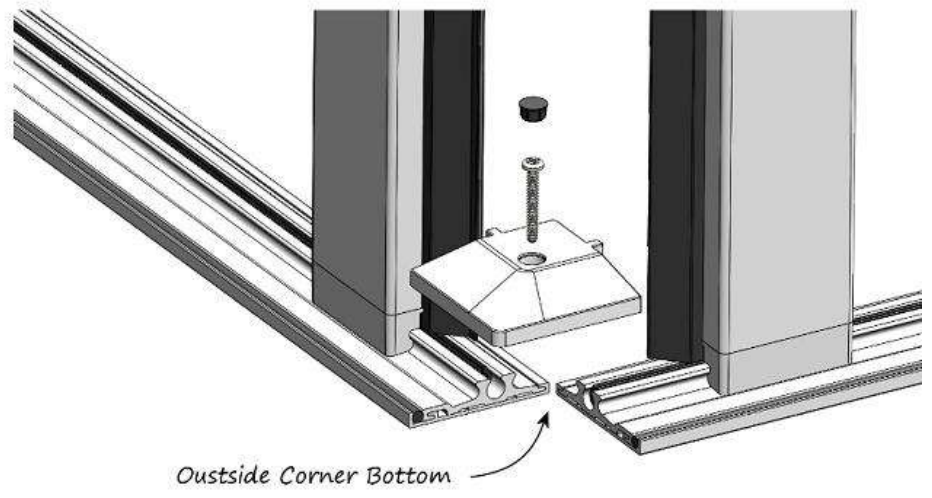
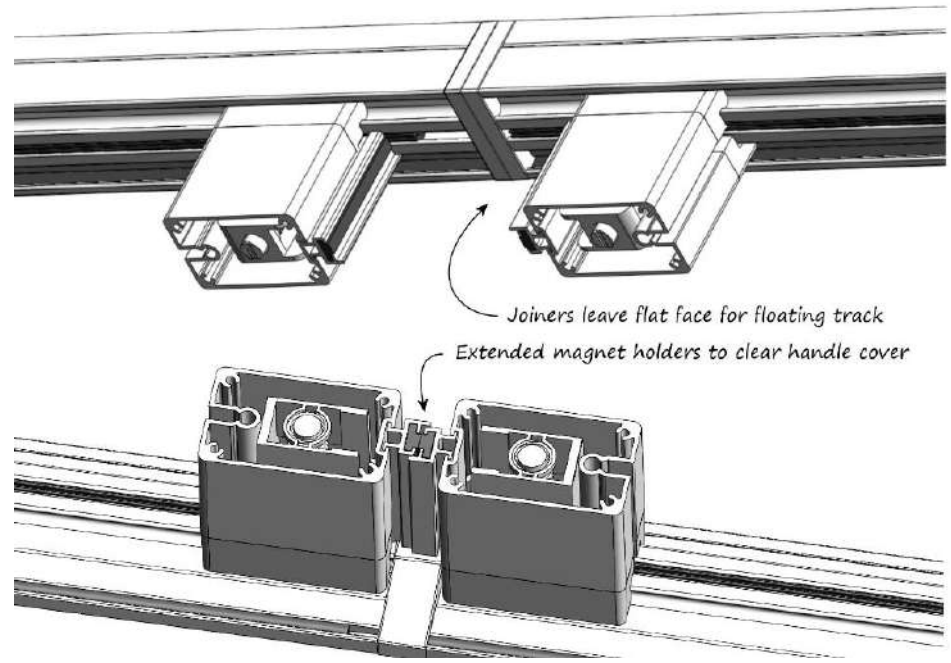
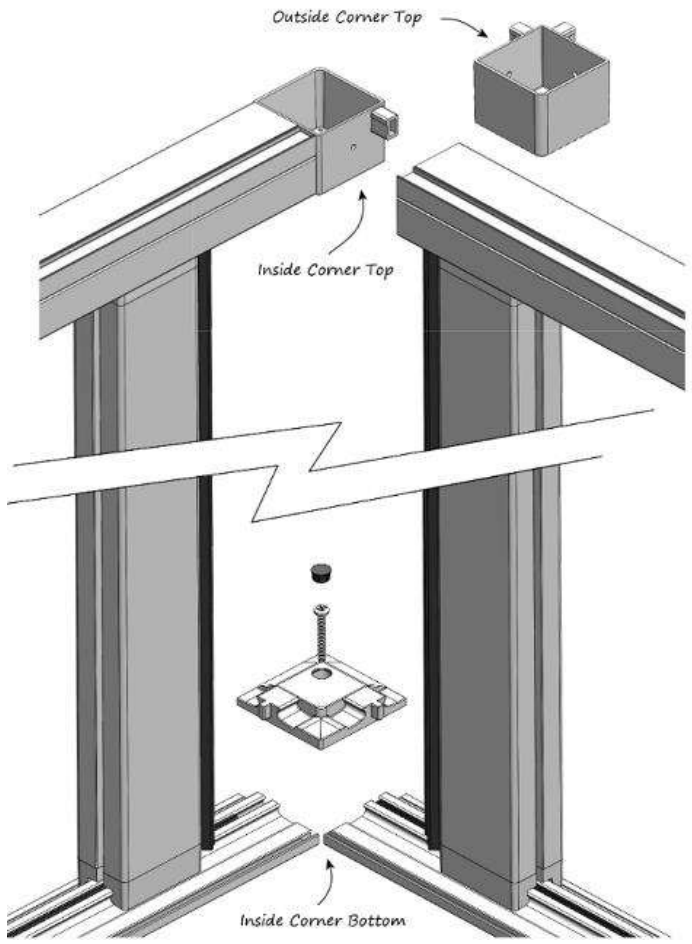

THE
HORIZON

UPPER track runner cut to fit between **upper endcap** and **latch**.

LOWER track runner cut to fit between **lower endcap spigot** and **latch**.



Slightly counter-sink.

Barely trim the corners off.

Deburr and clear debris.



DO NOT CUT TRACK RUNNERS TOO SHORT



1. Predrill holes like shown or in pairs

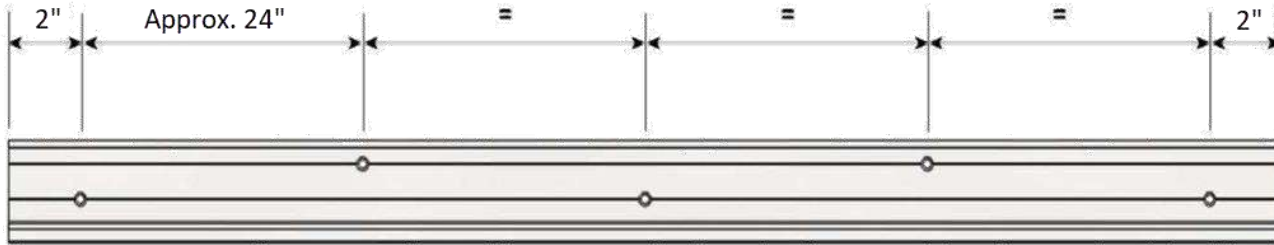

2. Countersink holes to suit desired FH screws

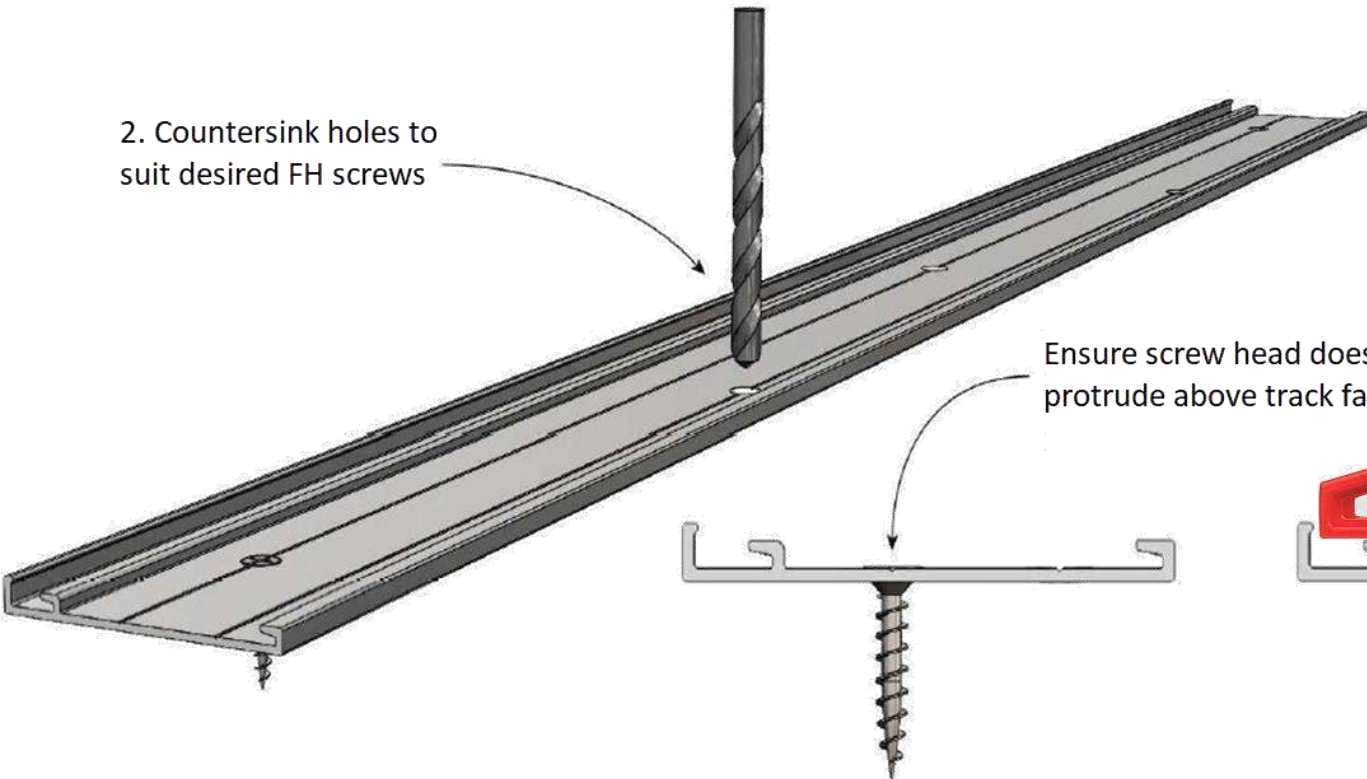

Ensure screw head does not protrude above track face

Check level front-to-back. Shim if necessary.





1. Insert **RED** wedge into handle to release brakes.

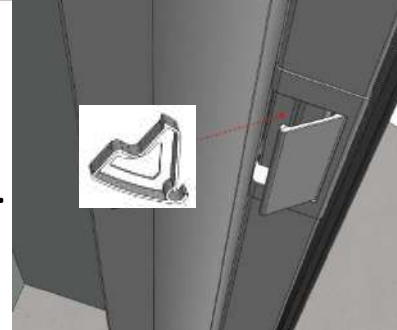

2. Fasten **track mount**. Bottom even with bottom of housing.

3. Lift **pullbar**. Slide **track runner** along zipper.

4. Slide track into place. Feed **track** through **pullbar**, pushing fully against **housing** – **no gaps.**

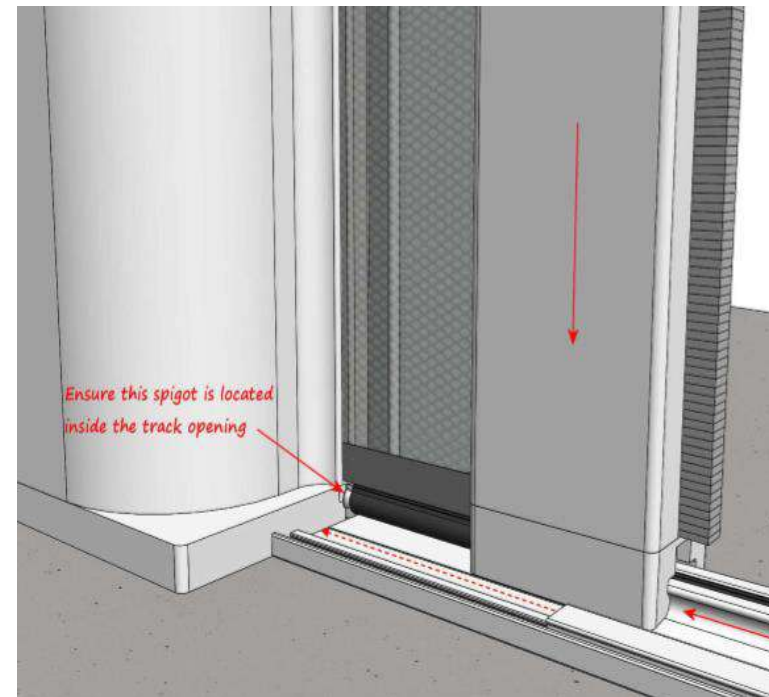
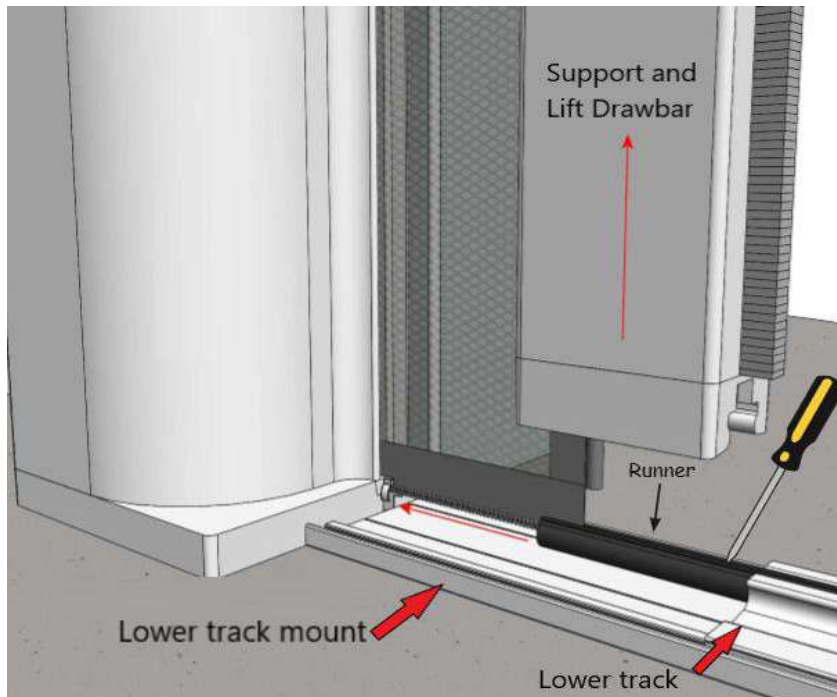

6. Interlock **track** and insert **spline** into groove while compressing it to allow for shrinkage.

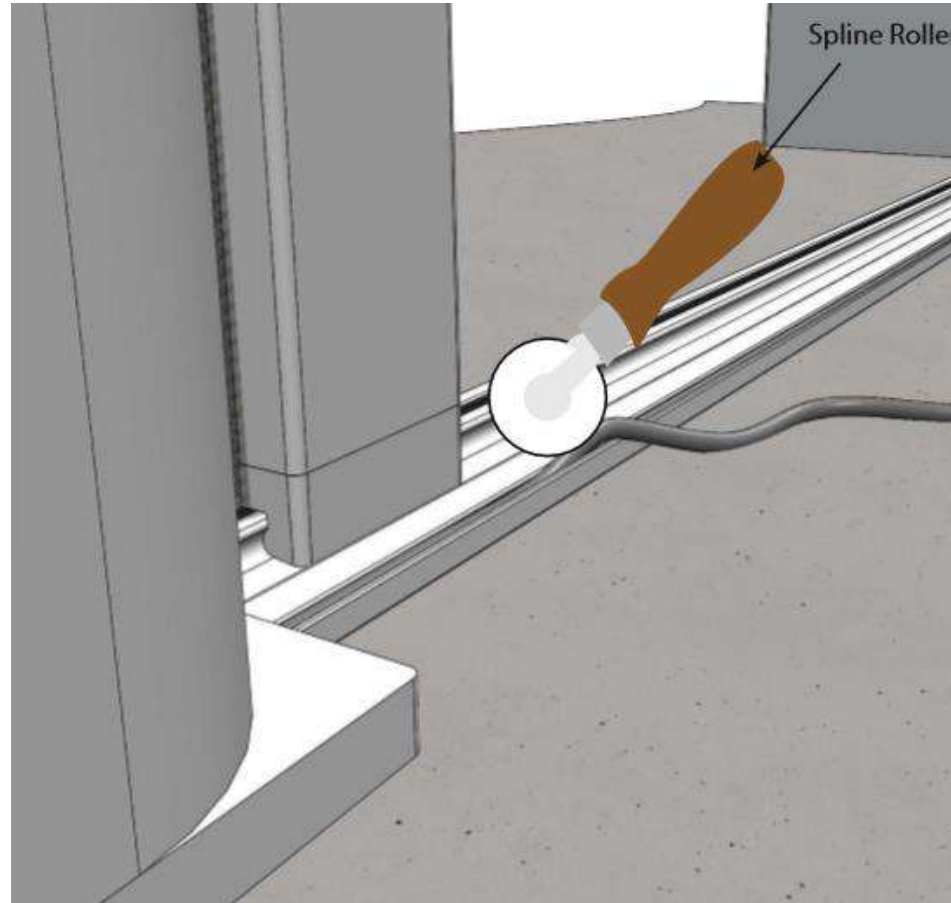

UPDATE

THE
HORIZON

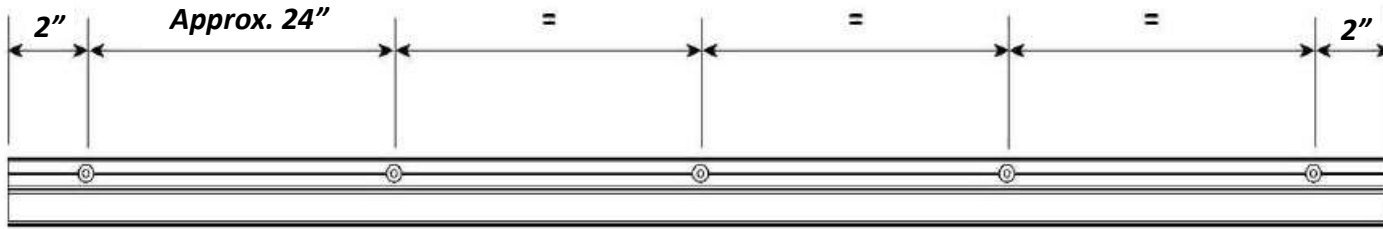

STEP 1

Drill 5/32" through **both** webs

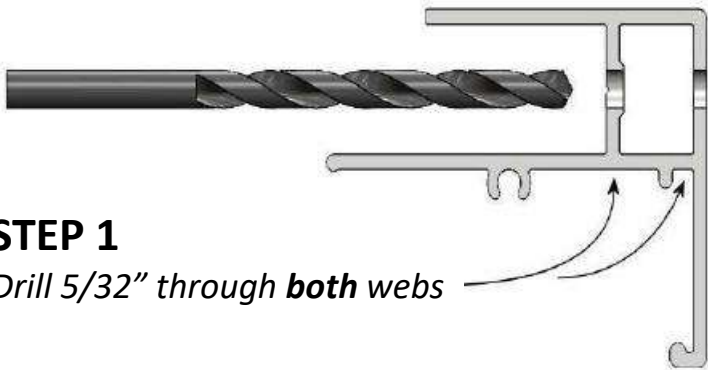

STEP 2

Drill 3/8" through **inner** web

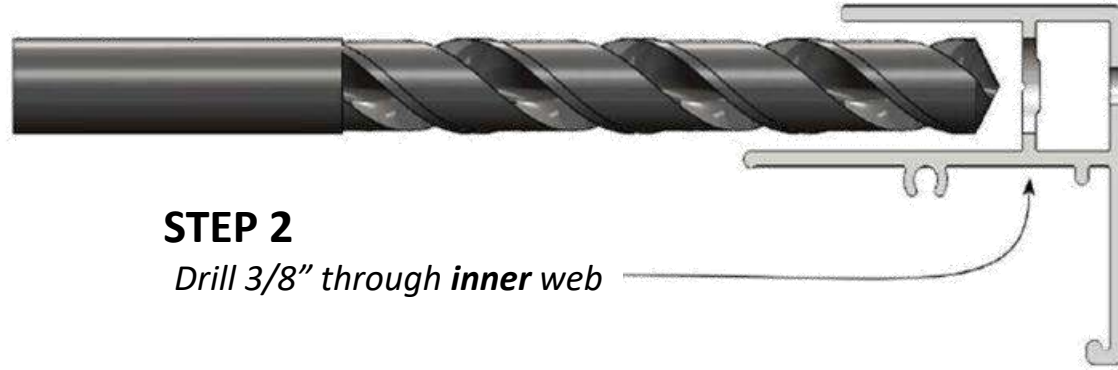

STEP 3

Remove outside burrs with countersink bit.



Upper Track Fixed

Insert **upper track fixed** into **housing endcap**. Ensure **alignment pin** is in hole.

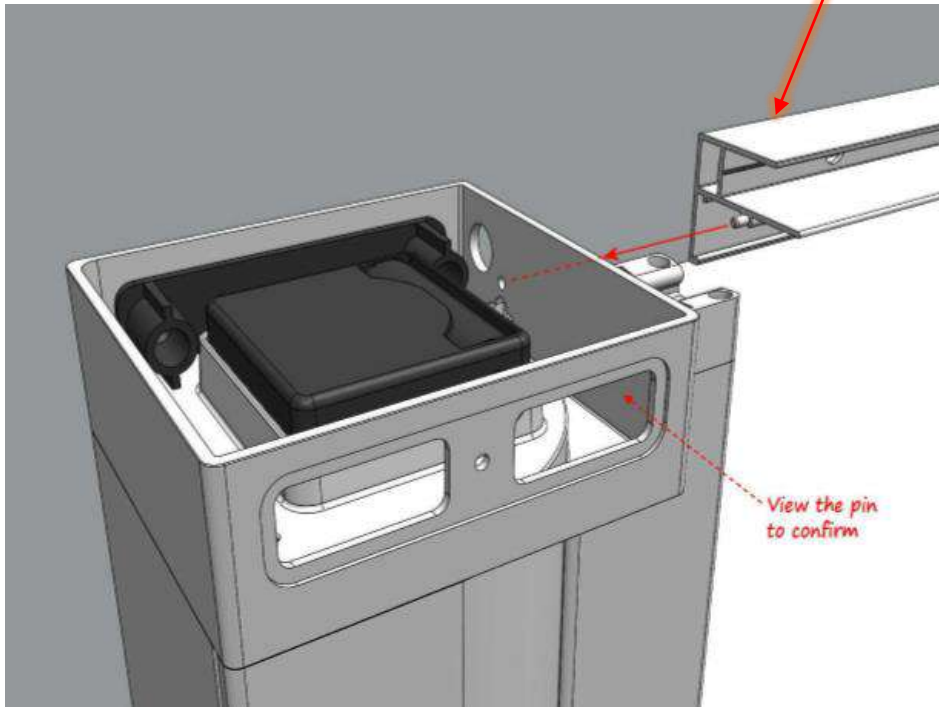

***Optional box channel** for an under-header fit. Affix *first* to header.

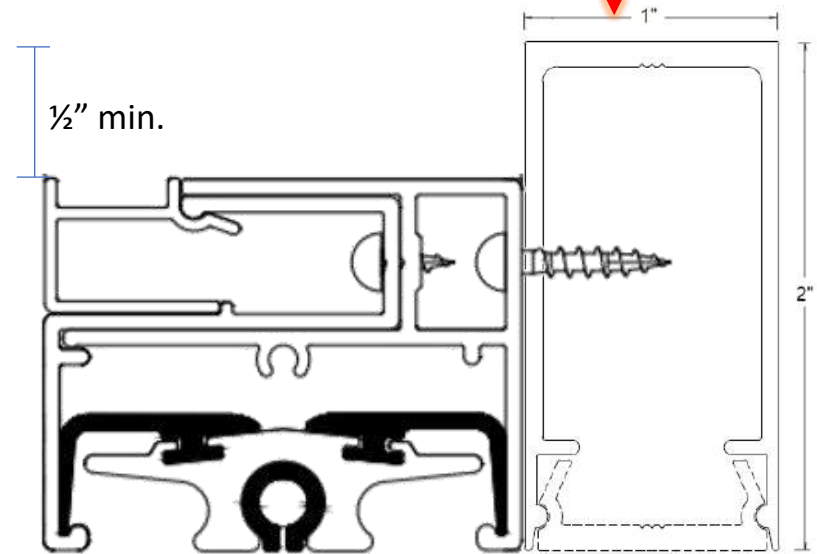

Affix upper track fixed using receiver channel as preacher stick.

Upper Track Fixed

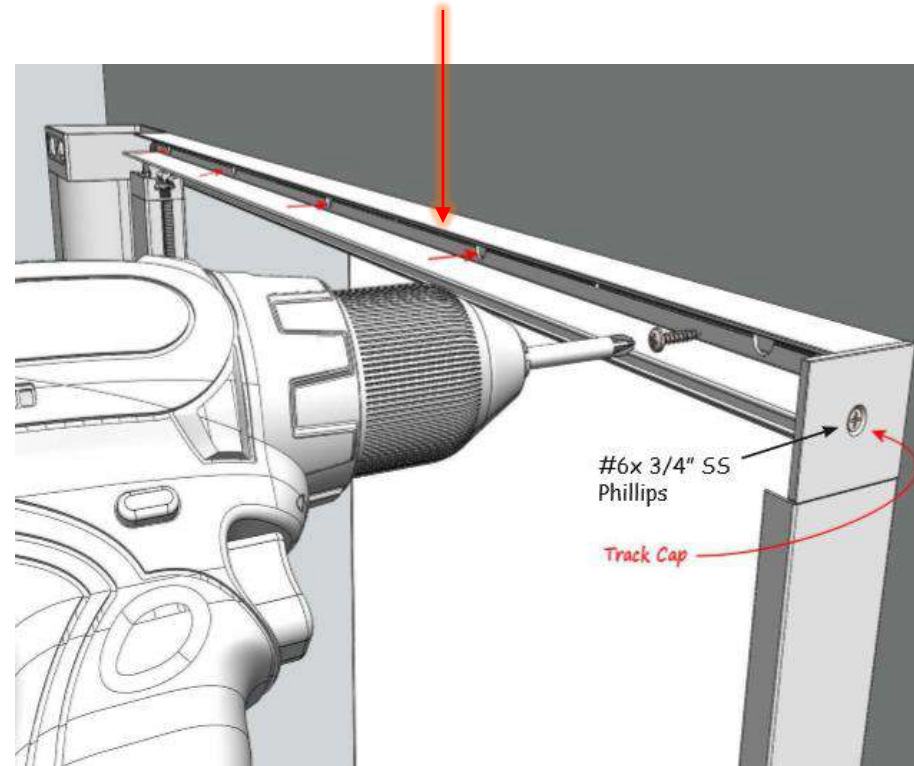
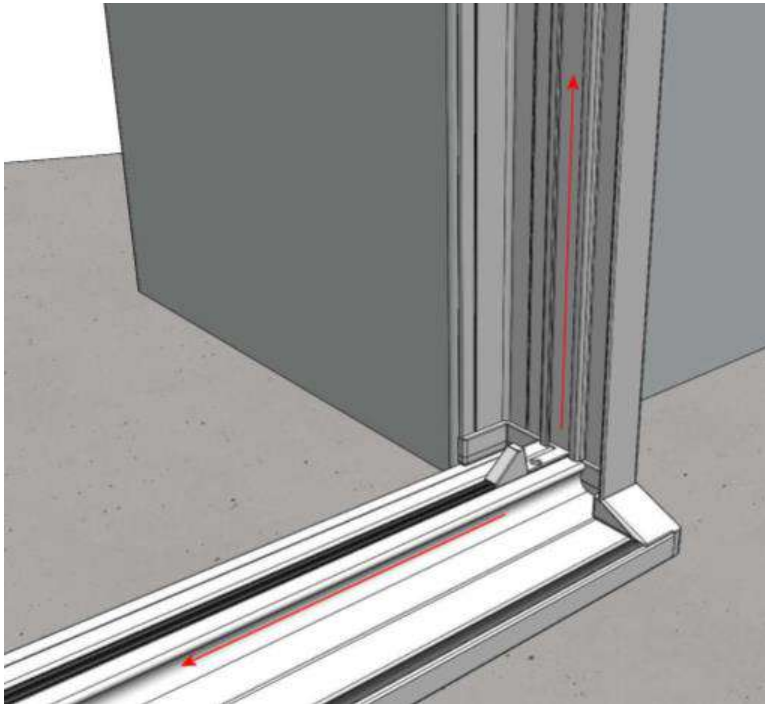

1. Feed **track runner** along zipper, then **track upper** through **pullbar endcap**. Push *fully* against **housing** – no gaps.

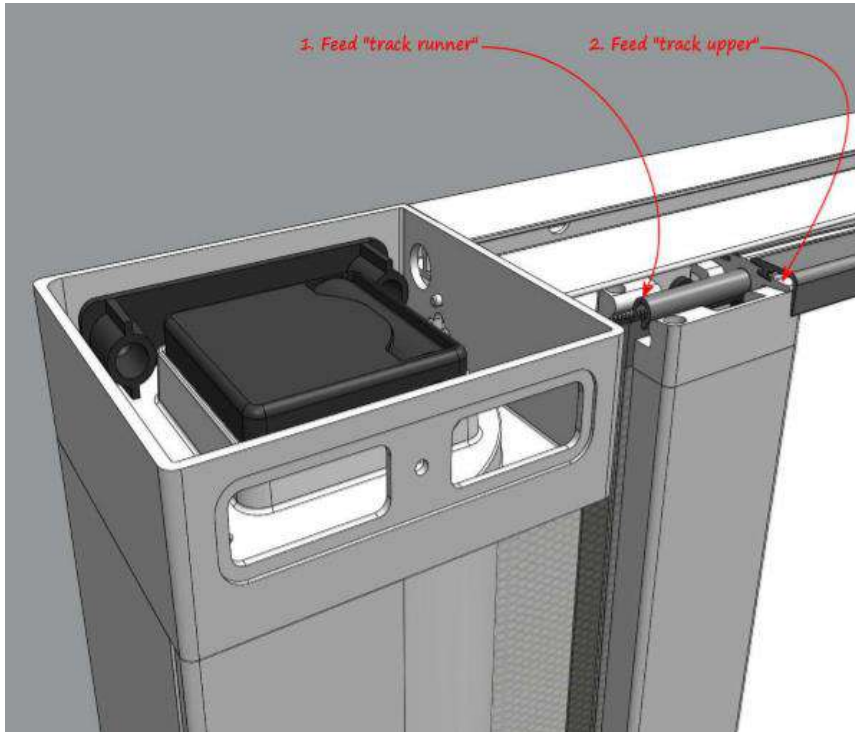

2. Place **upper track** into **upper track fixed**.

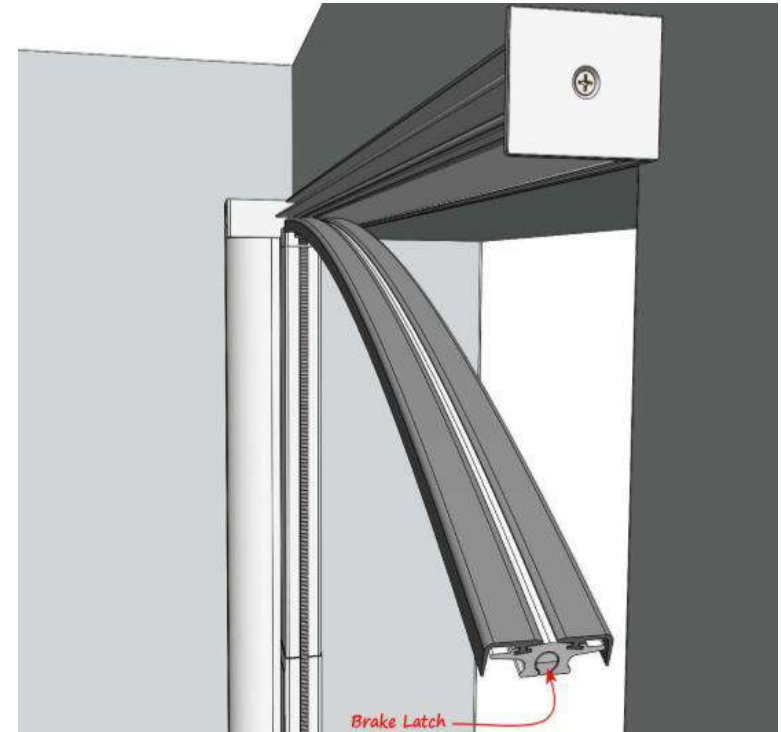



1. Fasten **upper track outer** to **track fixed** with & #8 x 1/2" ST screws
2. Spray dry silicone in **track runners**.
3. Retract screen fully, draw out 1' extra after each retraction, doing so until it reaches the receiver side. ***If resistance is felt, retract and slowly draw again.**
4. If the screen does not work, review the [Horizon Troubleshoot Guide](#). Otherwise, attach the **track filler** with a mallet .

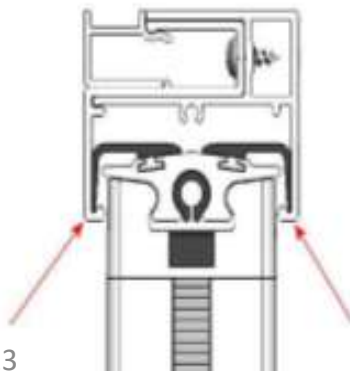
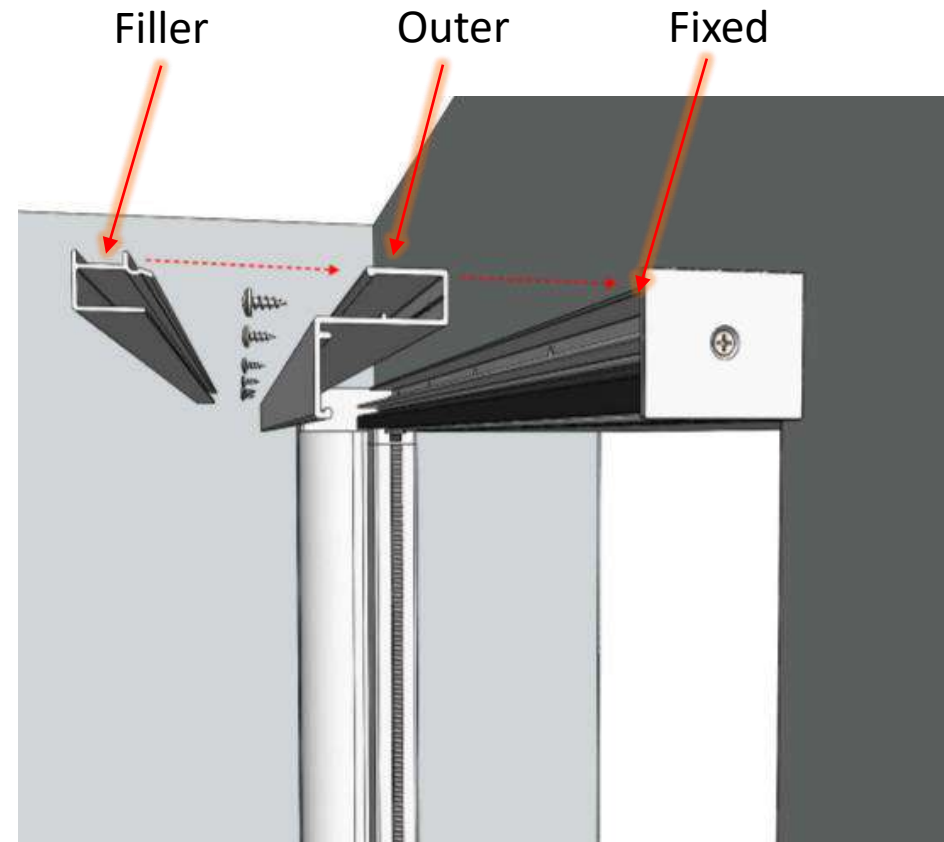

1. Position **receiver** and fasten with #6 PH painted screws (not shown) using screw guidelines.
2. Repeat test from previous page.

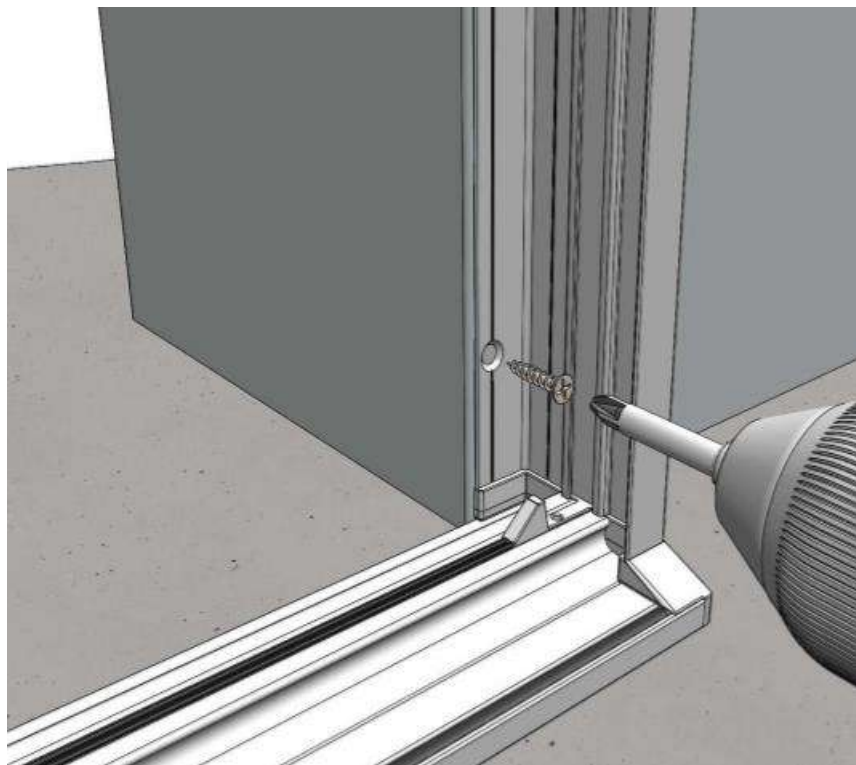

3. Apply **decals** over gearbox access window.
4. Put **endcap plug** on top of housing.
*If housing is “under-header”, put plug on *before* installing housing.

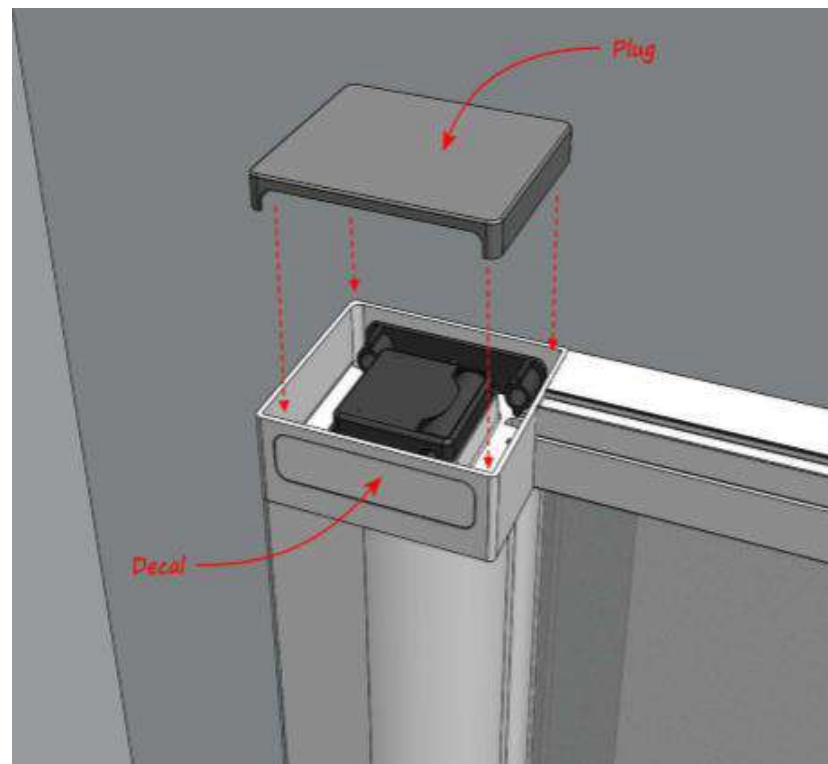

TEST THE UNIT



Check the following:	✓ or ✗
Tracks are level, parallel, and plumb side-to-side and front-to-back?	
Housing on the ground AND plumb?	
Housing mesh slot has not been squeezed during the install?	
Tracks are fully against the housing? No gap?	
Track runners are <i>not</i> cut too short? No gap?	
Zippers are following through the housing endcap keyholes?	
Track runners have been sprayed with dry silicone ?	

! If any problems are not resolved, call 604-299-4426, or email support@wizardscreens.com **before leaving site!**

If necessary, review [The Horizon Troubleshoot Manual](#)



Upper Track

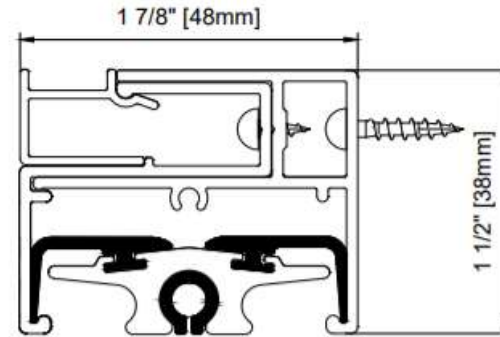
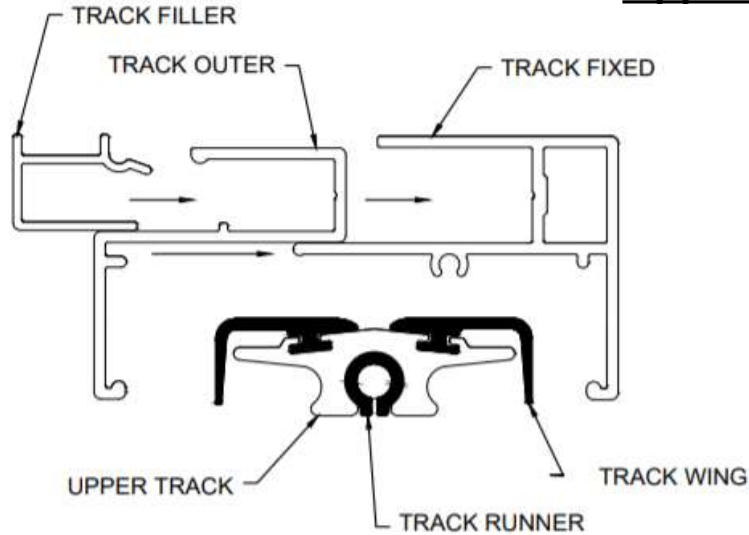

Lower Track

